

RTD WITH TAPPER THERMOWELL & ADJUSTABLE FLANGE

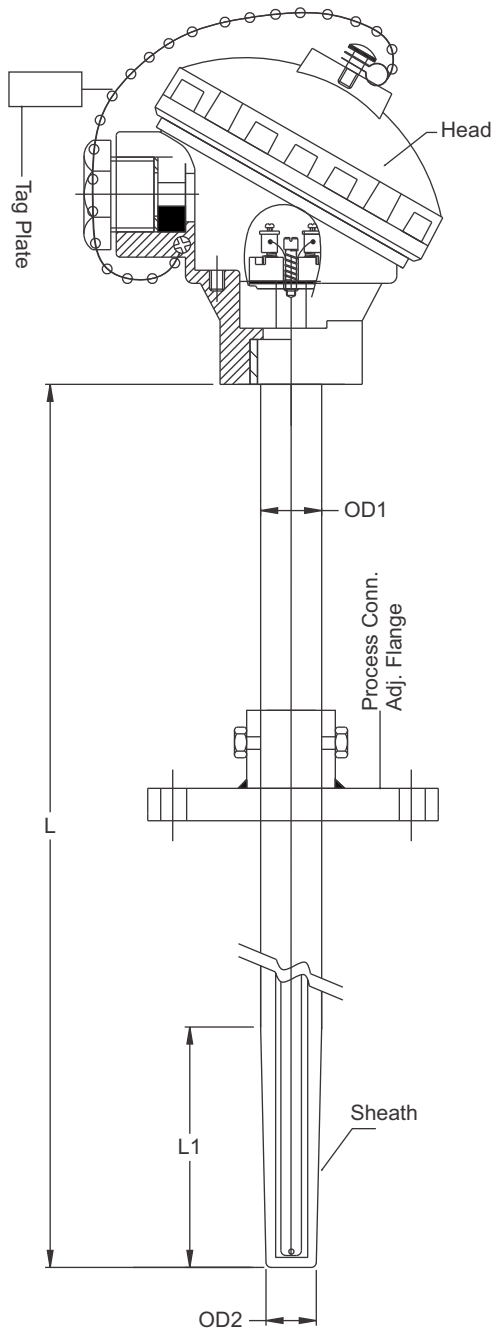

R-503

RTD Element		1	Pt-100x1, Simplex
		2	Pt-100x2, Duplex
		Other	Consult Factory
Termination Style		C	Connection Head IP-67
		D	Double entry Head IP-65
		EB	Ex-D IIB Zone 1&2
		EC	Ex-D IIC
		M	Miniature Head
		P	Plastic Head
		Other	Consult Factory
Junction Style		W2	2- Wire
		W3	3- Wire
		W4	4- Wire
Sheath "OD"		3	Ø3mm
		4.5	Ø4.5mm
		6	Ø6mm
		8	Ø8mm
		Other	Consult Factory
Sheath Material		316	SS 316
		Other	Consult Factory
Thermowell OD1 (mm)			
Thermowell OD2 (mm)			
Thermowell "ID" (mm)			
Outer Sheath Material		316	SS 316
		310	SS 310
		304	SS 304
		600	Inconel-600
		800	Inconel-800
		446	HRS- 446
		Other	Consult Factory
Process Conn.		Adj. Flange	1/2"
		# 150	3/4"
		# 300	1"
		# 400	1 1/2"
		# 600	1 1/4"
			2"
		Standard Adj. Flange P.C.D.-70mm	
Flange Material		316	SS 316
		310	SS 310
		304	SS 304
		C S	Cast Steel
		Other	Consult Factory
Taper Length (L1) (mm)			
Nominal Length of T/C "L" (mm)			